

# ES603B HF Motion Sensor User Manual

(new version of the ES608B)



## General

The ES603B is an active motion sensor that emits high-frequency waves (5.8GHz). The sensor detects the change in the echo return, and is sensitive to movement in its detection zone.

The ES603B is designed to be used in a device or system and must not be operated without appropriate protective covering.

If, after reviewing this guide, you require additional information or assistance please contact Eco Heat Equipment at info@ecosensor.co.za, +27 (0)861 999 887, or www.ecosensor.co.za.

## Technical Specifications

- Voltage: 220 – 240V/AC
- Frequency: 50/60Hz
- Working temperature: -15°C to 70°C
- Load: Incandescent max: 1 000W  
Fluorescent max: 600W  
LED max: 300W
- Detection Range: 2 – 10m
- Detection Angle: 360°
- Light level: 10 – 500 LUX
- Time setting: 10 seconds – 30 minutes
- Installation height: 2 – 4m (max)
- Motion Sensor HF system: 5.8GHz CW radar, ISM band
- Motion Sensor transmission power: <0.2mW RF power
- Dimensions: 71.8mm\* (L) x 41mm (W) x 39.8mm(H)  
(\* excludes mounting foot – total length 65.5mm)

## Safety

Any incorrect use or installation procedure not recommended by the manufacturer may cause fire, electrical shock or injury to persons. Disconnect power when working on electrical outlets or components.

Controlling a load in excess of the specified ratings will damage the unit and lights and could pose risk of fire and electric shock.

Do not install this unit to control a power socket.

**WARNING: THE ES608B IS DESIGNED TO BE A COMPONENT IN A DEVICE OR SYSTEM AND IS NOT SUITABLE TO BE USED IN ITS CURRENT FORM. ENSURE THE USE OF THE ES608B IS IN ACCORDANCE WITH NATIONAL AND LOCAL ELECTRICAL CODES AND STANDARDS. EQUIPMENT (such as access control systems, alarms, Wi-Fi routers, BMS etc.) WITH THE SAME BANDWIDTH AS THE SENSOR CAN CAUSE INTERFERENCE WITH THE SENSOR'S BEHAVIOUR.**

Note: Do not install the motion sensor on unstable or vibrating surfaces, or near doors and windows where outside movement may be detected. Motion may be detected through walls, ceilings, doors, drywall, wood or plastic.

## Sensor calibration:

Note: Allow up to 1 minute for the motion sensor to recalibrate after it has been connected for the very first time. This is only necessary during installation or when the mains supply is disconnected.

Note: After the connected device switches OFF, it takes approximately 4 seconds before it is able to start detecting movement again. The connected device will only switch on in response to movement once this period has elapsed.

## Settings

The three adjustments settings are as follows:

- Detection range: 2m to 10m
- Time setting range: 10 sec to 30 min
- Lux (light) sensitivity: 10 to 500 LUX

There are 8 settings on the motion sensor that control the range, time and lux.

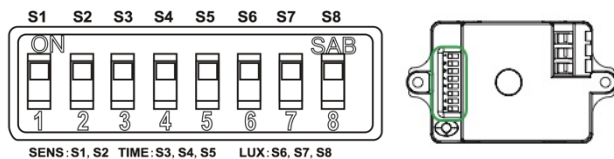

## Step 1 – Adjust the detection range of the motion sensor

The detection range is the term used to describe the radius of the circular detection zone produced on the ground after mounting the unit at a height of about 2.5m.

- ON position = "1"
- OFF position = "0"



S1	S2	RANGE
0	0	2m
0	1	5m
1	0	8m
1	1	10m

## Wire Diagram

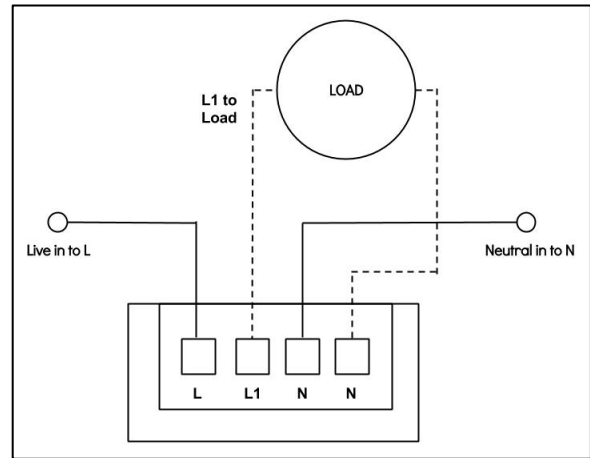

## Operation and Field of View

The motion sensor detects motion within its coverage area and controls the associated load connected to the sensor. For best performance, persons or objects moving towards the sensor are ideal. Detection is possible through wooden doors, panes of glass, dry wall, ceiling tiles, or thin brick walls. Beware of windows facing passages or roads.

### Ceiling Mount

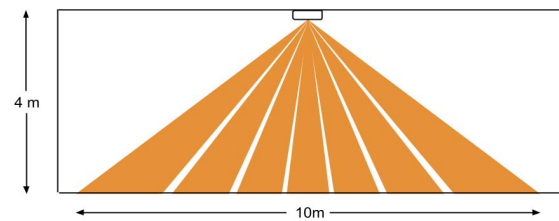

### Wall Mount (side view)

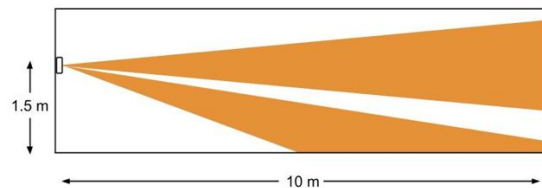

### Wall Mount (top view)

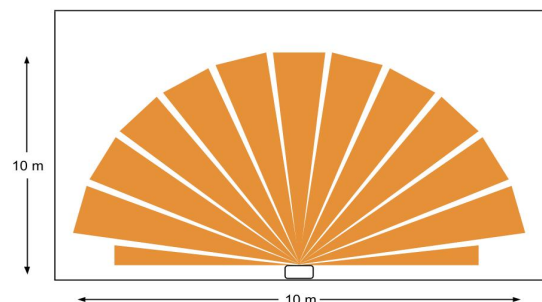

**Step 2 – Adjust the time setting of the motion sensor**

The time setting will determine the time that needs to lapse before the motion sensor switches off due to lack of movement in the detection area. Any movement detected during the time setting will restart the timer and keep the connected device on.  
ON position = "1"  
OFF position = "0"

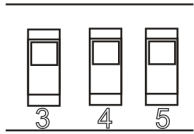

**SENS: S3, S4, S5**

S3	S4	S5	TIME
0	0	0	10s
0	0	1	1min
0	1	0	5min
0	1	1	10min
1	0	0	15min
1	0	1	20min
1	1	0	25min
1	1	1	30min

**Step 3 – Adjust the lux setting of the motion sensor (if applicable)**

The lux (light) sensitivity can be used to ensure the unit only operates during minimum lux settings. The lux setting can also be disabled by setting it to the '24hr' position, (S6="0", S7="0", S8="0") meaning the lux (light) level will have no effect on the operation of the unit.  
ON position = "1"  
OFF position = "0"

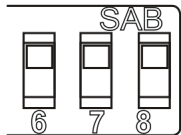

**LUX: S6, S7, S8**

S6	S7	S8	LUX
0	0	0	24H
0	0	1	10LUX
0	1	0	20LUX
0	1	1	50LUX
1	0	0	100LUX
1	0	1	200LUX
1	1	0	300LUX
1	1	1	500LUX

**Warranty**

The sensor has a three (3) year warranty after the date of the original purchase. Please keep your original invoice, as this will be required for any claims under this warranty. The warranty is a strictly carry in policy. (The sensor/s must be returned to Eco Heat offices for a claim to be processed).

The warranty does not cover:

- damage from misuse,
- neglect or abuse,
- products that have been modified in any way,
- shipping and handling cost associated with the product,
- damage resulting from accidents, lightning, fire, water, power surges, natural disasters and/or incorrect installation

For more information, view the Return/Refund Policy at [www.ecosensor.co.za](http://www.ecosensor.co.za).

Due to minor improvements in design or otherwise, the product you purchase may differ from the one shown in this leaflet. For more information or advice on this or any other Eco Heat Equipment products, visit [www.ecosensor.co.za](http://www.ecosensor.co.za) or phone +27 (0)861 999 887.

**Trouble Shooting**

Malfunction	Possible Cause	Remedy
The unit will not switch "on"	a. No mains power b. No movement is detected (in detection zone) c. Wrong LUX/LIGHT level setting d. Electrical circuitry faulty e. Electrical Installation not done correctly f. Unit may be faulty	a. Check mains power is on b. Move towards the unit (in detection zone) or increase the detection range settings c. Adjust setting on the LUX/LIGHT settings d. Refer to the 'Electrical Installation' section to ensure correct installation e. Have a certified electrician disconnect and test the unit f. Contact Eco Heat Equipment
Unit stays "on" permanently	a. Continuous movement in detection zone b. The sensor is not mounted correctly for reliable operation c. Wrong LUX/LIGHT level setting d. Time setting control is set too high e. Unit may be faulty	a. Check detection range setting and reduce detection range sensitivity b. Check detection range setting and mounting procedure c. Adjust setting on the LUX/LIGHT settings d. Adjust the time setting control e. Contact Eco Heat Equipment

Indemnity: The Author, and supplier, shall not be held liable for any loss, injury or damage, of whatsoever nature, whether consequential or not, either contractual sustained to, or caused by, or which may arise through the use of any comments, suggestions, circuitry, services or equipment offered for purchase. The User, indemnifies the author and supplier, and agrees not to hold him/her responsible for any damages, losses and/or liabilities (including legal costs on a scale as between attorney and user) arising from, or through the use of circuit diagrams, equipment and services, whether such circuit diagrams, equipment and services were used with the consent of the User or not. All risks attached to the use of circuit diagrams, equipment and the connection thereof to the User's equipment shall be deemed to have passed onto the User, once having purchased such equipment from the author or supplier

